



2012 PH

Test Paper Code: PH

Time: 3 Hours

Maximum Marks: 300

INSTRUCTIONS

1. This question-cum-answer booklet has **32** pages and has **25** questions. Please ensure that the booklet you have received contains all the questions.
2. Write your **Registration Number, Name and the name of the Test Centre** in the appropriate space provided on the right side with blue/black pen.
3. Write the answers to the objective questions against each Question No. in the **Answer Table for Objective Questions**, provided on Page No. **7**. Do not write anything else on this page.
4. Each objective question has **4 choices** for its answer: (A), (B), (C) and (D). Only **ONE** of them is the correct answer. There will be **negative marking** for wrong answers to objective questions. The following marking scheme for objective questions shall be used:
 - (a) For each correct answer, you will be awarded **6 (Six)** marks.
 - (b) For each wrong answer, you will be awarded **-2 (Negative two)** marks.
 - (c) Multiple answers to a question will be treated as a wrong answer i.e. **-2 (Negative two)** marks.
 - (d) For each unattempted question, you will be awarded **0 (Zero)** mark.
5. Answer the subjective question only in the space provided after each such question.
6. Do not write more than one answer for the same question. In case you attempt a subjective question more than once, please cancel the answer(s) you consider wrong. **Otherwise, the answer appearing last only will be evaluated.**
7. All answers must be written in blue/black/blue-black ink only. Sketch pen, pencil or ink of any other colour should **not** be used.
8. All rough work should be done in the space provided and be struck out finally.
9. No supplementary sheets will be provided to the candidates.
10. **Clip board, log tables, slide rule, calculator, cellular phone and electronic gadgets in any form are NOT allowed.**
11. The question-cum-answer booklet must be returned in its entirety to the Invigilator before leaving the examination hall. Do not remove any page from this booklet.
12. Special instructions/useful data are given overleaf.

2012 PH

READ INSTRUCTIONS ON THE LEFT SIDE OF THIS PAGE CAREFULLY

| REGISTRATION NUMBER | | | | | | |
|---------------------|--|--|--|--|--|--|
| | | | | | | |
| Name: | | | | | | |
| | | | | | | |
| Test Centre: | | | | | | |
| | | | | | | |

Do not write your Registration Number or Name anywhere else in this question-cum-answer booklet.

I have read all the instructions and shall abide by them.

.....
Signature of the Candidate

I have verified the information filled by the candidate above.

.....
Signature of the Invigilator

Special Instructions/ Useful Data

$$\nabla^2 A = \frac{\partial^2 A}{\partial x^2} + \frac{\partial^2 A}{\partial y^2} + \frac{\partial^2 A}{\partial z^2} = \frac{1}{r^2} \frac{\partial}{\partial r} \left(r^2 \frac{\partial A}{\partial r} \right) + \frac{1}{r^2 \sin \theta} \frac{\partial}{\partial \theta} \left(\sin \theta \frac{\partial A}{\partial \theta} \right) + \frac{1}{r^2 \sin^2 \theta} \frac{\partial^2 A}{\partial \phi^2}$$

Avogadro's number N_A = 6.02×10^{23} mole⁻¹

Boltzmann constant k_B = 1.38×10^{-23} J/K

Permittivity of free space ϵ_0 = 8.85×10^{-12} F/m

Molar gas constant R = 8.31 J/mol-K

Speed of light in vacuum c = 3×10^8 m/s

Planck's constant h = 6.63×10^{-34} J-s

log2 = 0.301

ln2 = 0.693

IMPORTANT NOTE FOR CANDIDATES

- Attempt **ALL** the 25 questions.
- Questions 1-15 (objective questions) carry six marks each and questions 16-25 (subjective questions) carry twenty one marks each.
- Write the answers to the objective questions in the Answer Table for Objective Questions provided on page 7 only.

Q.1 Given a function $f(x,t)$ of both position x and time t , the value of $\frac{\partial \dot{f}}{\partial \dot{x}}$ (where

$$\dot{f} = \frac{df(x,t)}{dt}, \quad \dot{x} = \frac{dx}{dt}) \text{ is}$$

- (A) $\frac{\partial^2 f}{\partial x^2}$ (B) $\frac{\partial f}{\partial x}$ (C) $\frac{\dot{f}}{\dot{x}}$ (D) $\frac{df}{dx}$

Q.2 If \vec{F} is a constant vector and \vec{r} is the position vector then $\vec{\nabla}(\vec{F} \cdot \vec{r})$ would be

- (A) $(\vec{\nabla} \cdot \vec{r})\vec{F}$ (B) \vec{F} (C) $(\vec{\nabla} \cdot \vec{F})\vec{r}$ (D) $|\vec{r}| \vec{F}$

Q.3 Three masses m , $2m$ and $3m$ are moving in x - y plane with speeds $3u$, $2u$ and u , respectively, as shown in the figure. The three masses collide at the same time at P and stick together. The velocity of the resulting mass would be

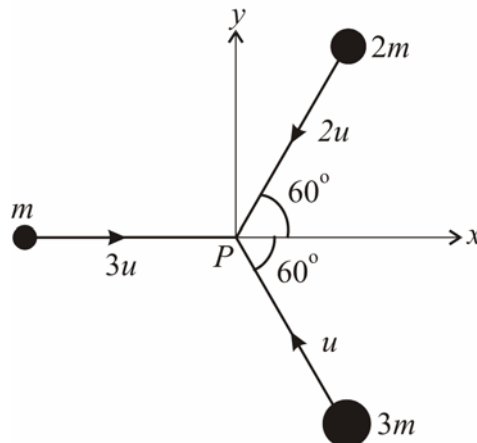

- (A) $\frac{u}{12}(\hat{x} + \sqrt{3}\hat{y})$ (B) $\frac{u}{12}(\hat{x} - \sqrt{3}\hat{y})$ (C) $\frac{u}{12}(-\hat{x} + \sqrt{3}\hat{y})$ (D) $\frac{u}{12}(-\hat{x} - \sqrt{3}\hat{y})$

Q.4 The figure shows a thin square sheet of metal of uniform density along with possible choices for a set of principal axes (indicated by dashed lines) of the moment of inertia, lying in the plane of the sheet. The correct choice(s) for the principal axes would be

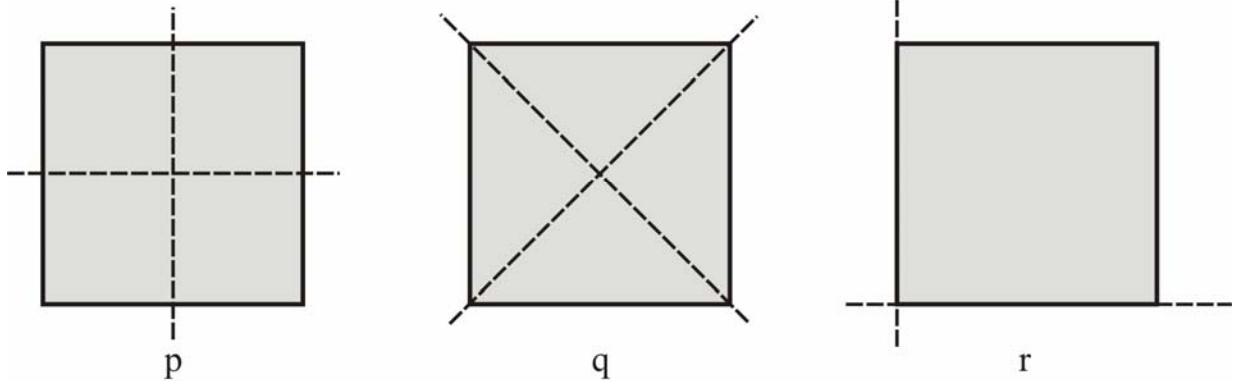

- (A) p, q, and r (B) p and r (C) p and q (D) p only

Q.5 A lightly damped harmonic oscillator loses energy at the rate of 1% per minute. The decrease in amplitude of the oscillator per minute will be closest to

- (A) 0.5% (B) 1% (C) 1.5% (D) 2%

Q.6 A parallel plate air-gap capacitor is made up of two plates of area 10 cm^2 each kept at a distance of 0.88 mm . A sine wave of amplitude 10 V and frequency 50 Hz is applied across the capacitor as shown in the figure. The amplitude of the displacement current density (in mA/m^2) between the plates will be closest to

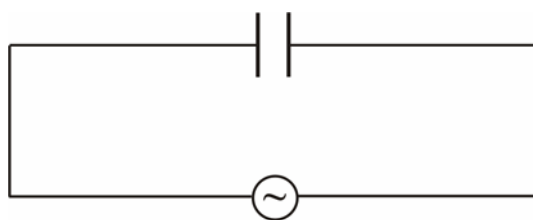

- (A) 0.03 (B) 0.30 (C) 3.00 (D) 30.00

Space for rough work

- Q.7 A tiny dust particle of mass 1.4×10^{-11} kg is floating in air at 300 K. Ignoring gravity, its rms speed (in $\mu\text{m/s}$) due to random collisions with air molecules will be closest to
- (A) 0.3 (B) 3 (C) 30 (D) 300
- Q.8 When the temperature of a blackbody is doubled, the maximum value of its spectral energy density, with respect to that at initial temperature, would become
- (A) $\frac{1}{16}$ times (B) 8 times (C) 16 times (D) 32 times
- Q.9 Light takes 4 hours to cover the distance from Sun to Neptune. If you travel in a spaceship at a speed $0.99c$ (where c is the speed of light in vacuum), the time (in minutes) required to cover the same distance measured with a clock on the spaceship will be approximately
- (A) 34 (B) 56 (C) 85 (D) 144
- Q.10 ${}^{60}_{27}\text{Co}$ is a radioactive nucleus of half-life $2\ln 2 \times 10^8$ s. The activity of 10g of ${}^{60}_{27}\text{Co}$ in disintegrations per second is
- (A) $\frac{1}{5} \times 10^{10}$ (B) 5×10^{10} (C) $\frac{1}{5} \times 10^{14}$ (D) 5×10^{14}
- Q.11 An X-ray beam of wavelength 1.54 \AA is diffracted from the (110) planes of a solid with a cubic lattice of lattice constant 3.08 \AA . The first-order Bragg diffraction occurs at
- (A) $\sin^{-1}\left(\frac{1}{4}\right)$ (B) $\sin^{-1}\left(\frac{1}{2\sqrt{2}}\right)$ (C) $\sin^{-1}\left(\frac{1}{2}\right)$ (D) $\sin^{-1}\left(\frac{1}{\sqrt{2}}\right)$

Space for rough work

Q.12 The Boolean expression $P + \bar{P}Q$, where P and Q are the inputs to a circuit, represents the following logic gate

- (A) *AND* (B) *NAND* (C) *NOT* (D) *OR*

Q.13 **Group I** contains x - and y - components of the electric field and **Group II** contains the type of polarization of light.

Group I

Group II

P. $E_x = \frac{E_0}{\sqrt{2}} \cos(\omega t + kz)$
 $E_y = E_0 \sin(\omega t + kz)$

1. Linearly Polarized

Q. $E_x = E_0 \sin(\omega t + kz)$
 $E_y = E_0 \cos(\omega t + kz)$

2. Circularly Polarized

R. $E_x = E_1 \sin(\omega t + kz)$
 $E_y = E_2 \sin(\omega t + kz)$

3. Unpolarized

S. $E_x = E_0 \sin(\omega t + kz)$
 $E_y = E_0 \sin(\omega t + kz + \frac{\pi}{4})$

4. Elliptically Polarized

The correct set of matches is

(A) $P \rightarrow 4$; $Q \rightarrow 2$; $R \rightarrow 4$; $S \rightarrow 1$

(B) $P \rightarrow 1$; $Q \rightarrow 3$; $R \rightarrow 1$; $S \rightarrow 4$

(C) $P \rightarrow 4$; $Q \rightarrow 2$; $R \rightarrow 1$; $S \rightarrow 4$

(D) $P \rightarrow 3$; $Q \rightarrow 1$; $R \rightarrow 3$; $S \rightarrow 2$

Space for rough work

Q.14 For a liquid to vapour phase transition at T_{tr} , which of the following plots between specific Gibbs free energy g and temperature T is correct?

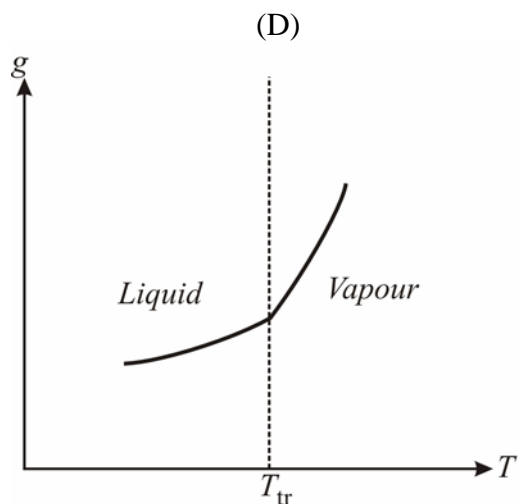
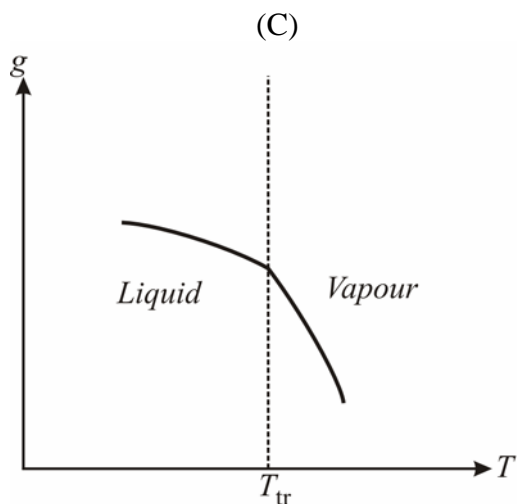
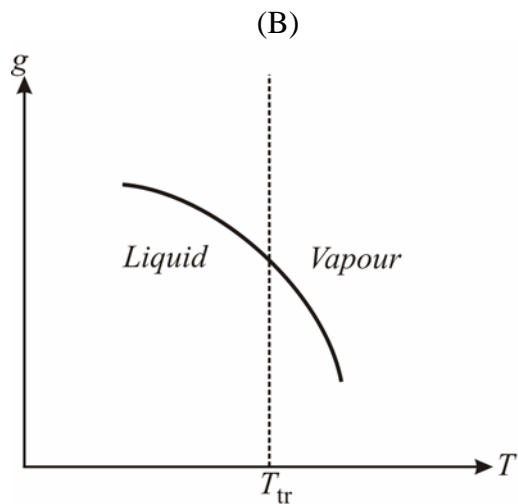
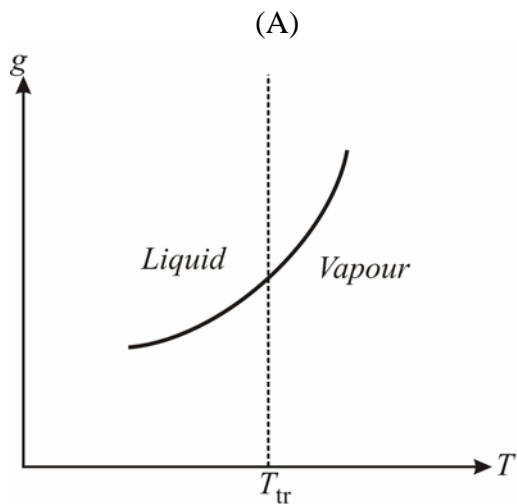

Space for rough work

- Q.15 A segment of a circular wire of radius R , extending from $\theta=0$ to $\pi/2$, carries a constant linear charge density λ . The electric field at origin O is

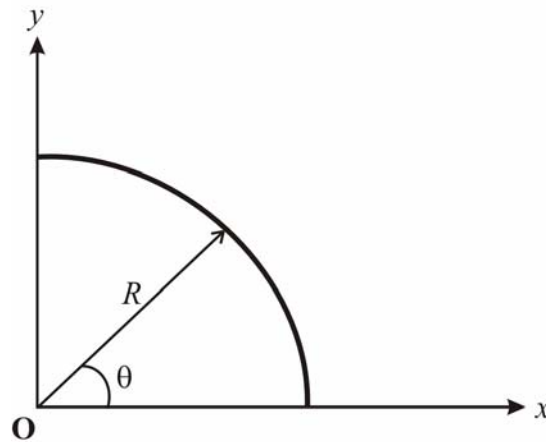

(A) $\frac{\lambda}{4\pi\epsilon_0 R}(-\hat{x} - \hat{y})$

(B) $\frac{\lambda}{4\pi\epsilon_0 R}\left(-\frac{1}{\sqrt{2}}\hat{x} - \frac{1}{\sqrt{2}}\hat{y}\right)$

(C) $\frac{\lambda}{4\pi\epsilon_0 R}\left(-\frac{1}{2}\hat{x} - \frac{1}{2}\hat{y}\right)$

(D) 0

Space for rough work

Answer Table for Objective Questions

Write the Code of your chosen answer only in the ‘Answer’ column against each Question Number. Do not write anything else on this page.

| Question Number | Answer | Do not write in this column |
|-----------------|--------|-----------------------------|
| 01 | | |
| 02 | | |
| 03 | | |
| 04 | | |
| 05 | | |
| 06 | | |
| 07 | | |
| 08 | | |
| 09 | | |
| 10 | | |
| 11 | | |
| 12 | | |
| 13 | | |
| 14 | | |
| 15 | | |

FOR EVALUATION ONLY

| | | | |
|-----------------------------------|--|-------|-------|
| Number of Correct Answers | | Marks | (+) |
| Number of Incorrect Answers | | Marks | (-) |
| Total Marks in Question Nos. 1-15 | | | () |

Q.16 The P - V diagram below represents an ideal monatomic gas cycle for 1 mole of a gas. In terms of the gas constant R , calculate the temperatures at the points J, K, L and M. Also calculate the heat rejected and heat absorbed during the cycle, and the efficiency of the cycle. (21)

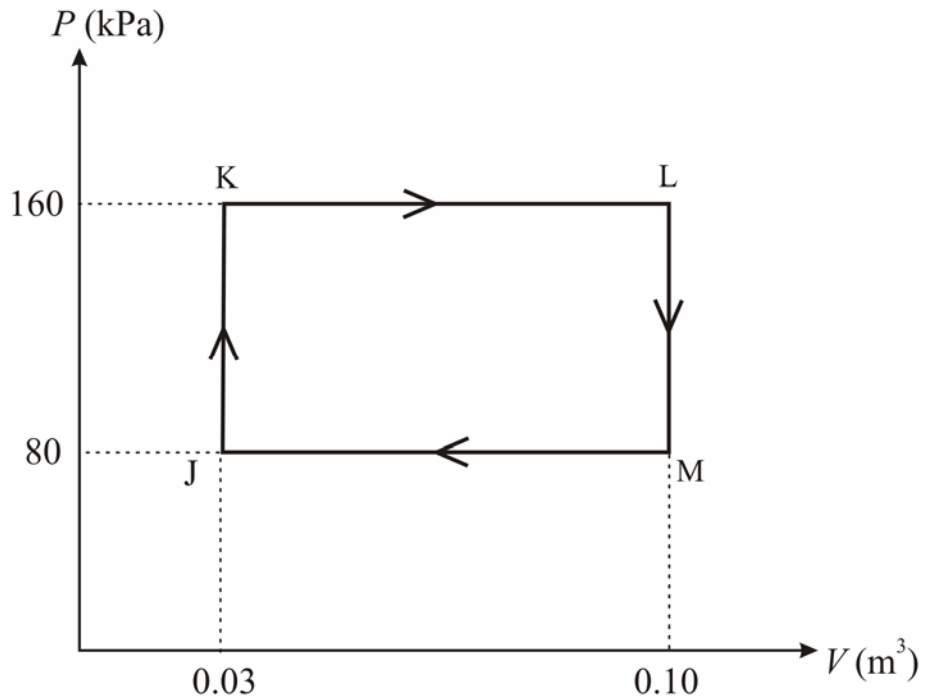



Q.17 2 kg of a liquid (specific heat = $2000 \text{ J K}^{-1} \text{ kg}^{-1}$, independent of temperature) is heated from 200 K to 400 K by either of the following two processes P_1 and P_2 :

P_1 : bringing it in contact with a reservoir at 400 K.

P_2 : bringing it first in contact with a reservoir at 300 K till equilibrium is reached, and then bringing it in contact with another reservoir at 400 K.

Calculate the change in the entropy of the liquid and that of the universe in processes P_1 and P_2 . Neglect any change in volume of the liquid. (21)



Q.18 (a) Two concentric, conducting spherical shells of radii R_1 and R_2 ($R_1 < R_2$) are maintained at potentials V_1 and V_2 , respectively. Find the potential and electric field in the region $R_1 < r < R_2$. (12)

(b) A polarized dielectric cube of side l is kept on the x - y plane as shown. If the polarization in the cube is $\vec{P} = k x \hat{x}$, where k is a positive constant, then find all the bound surface charge densities and volume charge density. (9)

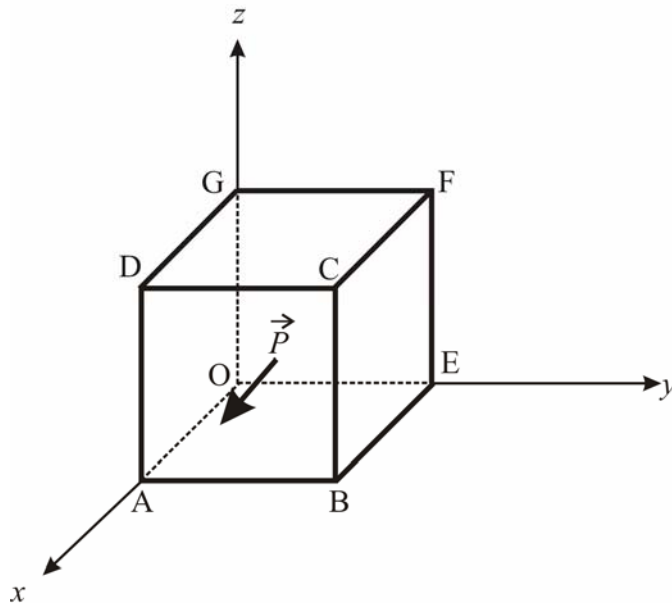



- Q.19 A water cannon starts shooting a jet of water horizontally, at $t = 0$, into a heavy trolley of mass M placed on a horizontal ground. The nozzle diameter of the water cannon is d , the density of water is ρ , and the speed of water coming out of the nozzle is u . Find the speed of the trolley as a function of time. Assume that all the water from the jet is collected in the trolley. Neglect all frictional losses. (21)

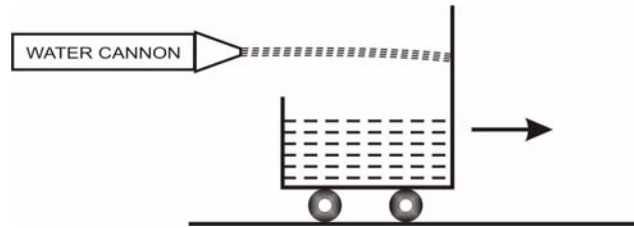



- Q.20 A long straight solenoid of radius R and n turns per unit length carries a current $I = \alpha t$, where α is a constant. t is time and remains finite. The axis of the solenoid is along the z -axis. Find the magnetic field, electric field and the Poynting vector inside the solenoid. Show these vectors at some instant t_1 at any point (i) on the axis of the solenoid, and (ii) at a distance $r (< R)$ from the axis.

(21)



Q.21 In the operational amplifier circuit shown below, input voltages $V_1 = \frac{2}{3}$ V and $V_2 = \frac{1}{2}$ V are applied.

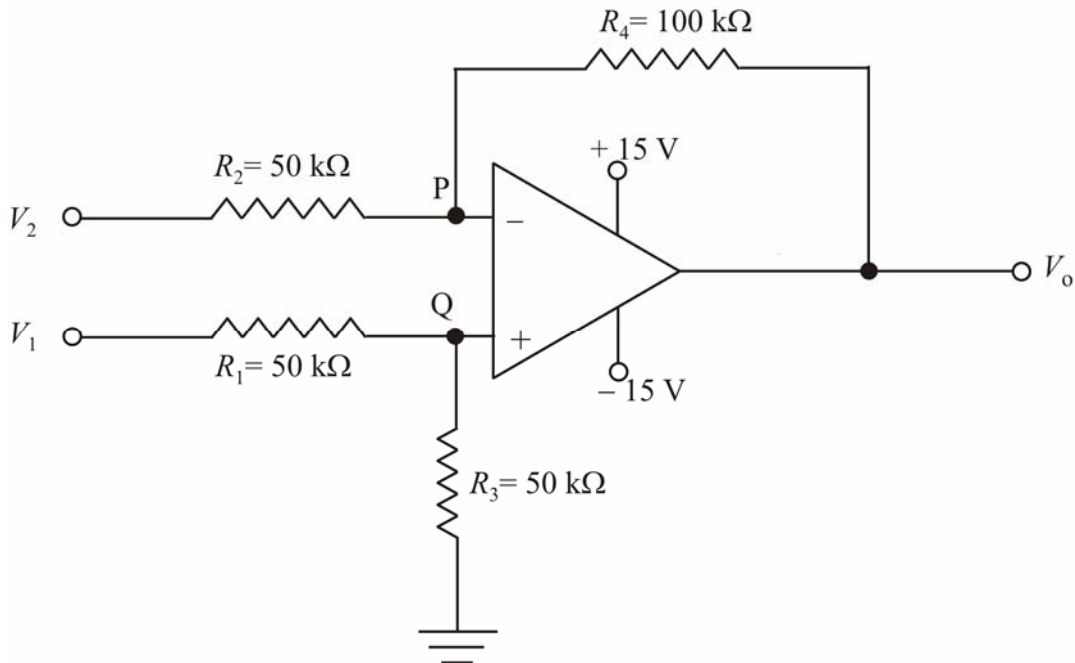

- (a) Determine the current flowing through resistance R_4 and the output voltage V_o . (12)
- (b) In the above circuit, if V_1 is grounded and square pulses of peak voltage 1V and frequency 100 Hz are applied at V_2 , determine the voltage and phase change of the output pulses. (9)



Q.22 A particle of mass m is confined in a potential-box of sides L_x , L_y , and L_z , as shown in the figure. By solving the Schrödinger equation of the particle, find its eigenfunctions and energy eigenvalues. (21)

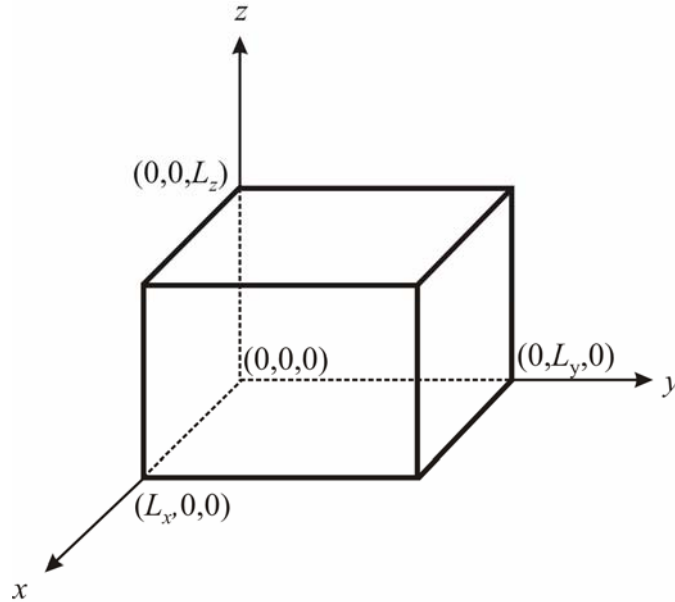



Q.23 A particle of mass m and charge q moves in the presence of a time-independent magnetic field $\vec{B}(\vec{r})$. Set up Newton's equation of motion for the particle.

Since for a magnetic field $\vec{\nabla} \cdot \vec{B} = 0$, one can write $\vec{B} = \vec{\nabla} \times \vec{A}$, where \vec{A} is a function of position. Calculate $\frac{d\vec{A}}{dt}$ as seen by the moving particle. Show that $\frac{d}{dt}(\vec{p} + q\vec{A})$, where \vec{p} is the momentum of the particle, can be written as q times the gradient of a function. (21)



Q.24 Consider a periodic function $f(x)$, with periodicity 2π ,

$$f(x) = \begin{cases} c & 0 \leq x < \pi \\ 0 & \pi \leq x < 2\pi, \end{cases}$$

where c is a constant.

(a) Expand $f(x)$ in a Fourier series. (12)

(b) From the result obtained in (a), show that

$$\frac{\pi}{4} = 1 - \frac{1}{3} + \frac{1}{5} - \frac{1}{7} + \frac{1}{9} - \dots. \quad (9)$$



Q.25 Two orthogonally polarized beams (each of wavelength $0.5 \mu\text{m}$ and with polarization marked in the figure) are incident on a two-prism assembly and emerge along x -direction, as shown. The prisms are of identical material and n_o and n_e are the refractive indices of the o -ray and e -ray, respectively. Use $\sin \phi = \frac{\sin \theta}{3}$, and $n_o = \frac{\sqrt{3}+1}{4}$.

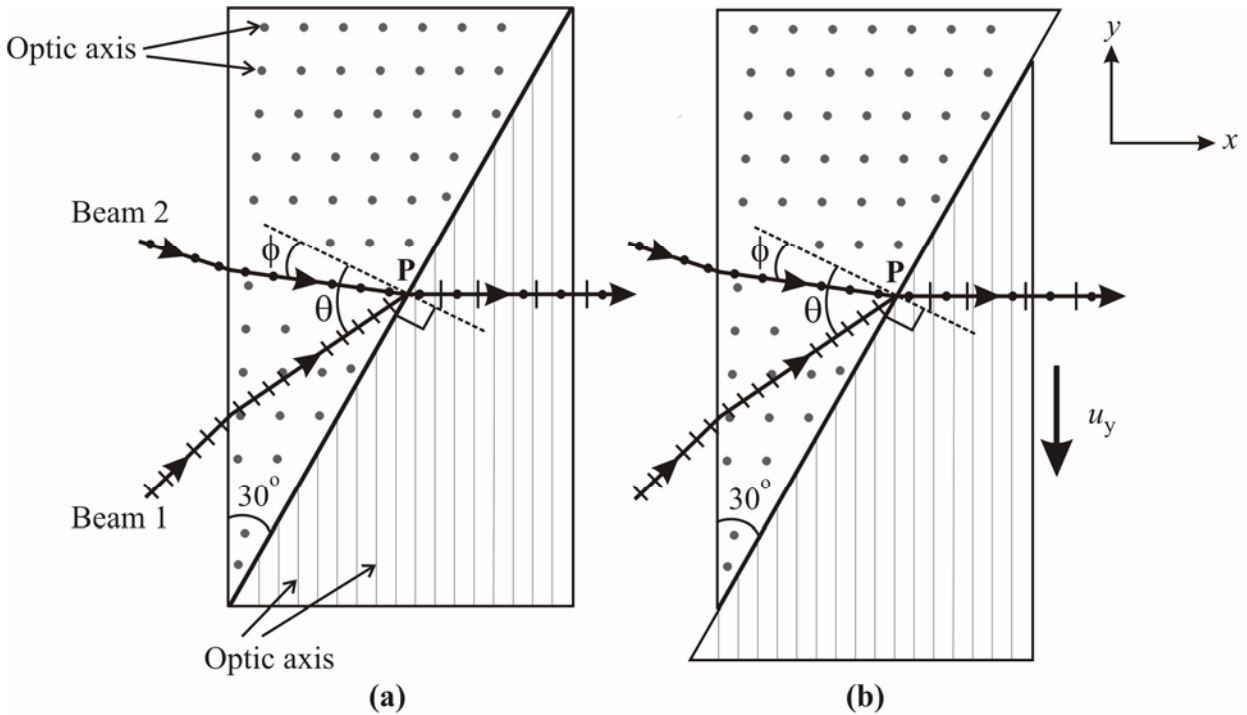

- (a) Find the value of θ and n_e . (9)
- (b) If the right hand side prism starts sliding down with the vertical component of the velocity $u_y = 1 \mu\text{m/s}$, what would be the minimum time after which the state of polarization of the emergent beam would repeat itself? (12)





Space for rough work



Space for rough work



Space for rough work



Space for rough work



Space for rough work

| | |
|---|------------------|
| 2012 PH Objective Part (Question Number 1 – 15) | |
| Total Marks | Signature |
| | |

| | | | | | |
|---------------------------------------|--------------|--|------------------------|--------------|--|
| Subjective Part | | | | | |
| Question Number | Marks | | Question Number | Marks | |
| 16 | | | 21 | | |
| 17 | | | 22 | | |
| 18 | | | 23 | | |
| 19 | | | 24 | | |
| 20 | | | 25 | | |
| Total Marks in Subjective Part | | | | | |

| | | |
|--|---|--|
| Total (Objective Part) | : | |
| Total (Subjective Part) | : | |
| Grand Total | : | |
| Total Marks (in words) | : | |
| Signature of Examiner(s) | : | |
| Signature of Head Examiner(s) | : | |
| Signature of Scrutinizer | : | |
| Signature of Chief Scrutinizer | : | |
| Signature of Coordinating Head Examiner | : | |

